

MD-O PRESENCE DETECTOR

IP20



The MD-O is an intelligent, fully digital presence detector for office lighting. The sensor excels with its speed: MD-O reacts to a unique combination of motion and sound. The light is switched on immediately as soon as someone enters an office and stays on while someone is working quietly. If a radio is left on after working hours, then the lighting will be switched off.

Veko offers a warranty for as much as five years. To detect motion, the MD-O uses an extremely sensitive infrared (PIR) sensor. It interprets a change in the thermal image as motion. The MD-O offers a twilight sensor and nine levels for turn-off delay. You will always have the required amount of light in your office.

Technical information

Diameter (mm)	Build-in: 88.7 mm, Surface mount: 109.3 mm
Wattage (W)	0.5 W < 4 W (off < on)
Voltage (V)	230 V
Frequency (Hz)	50 Hz
Circuit	6A: Cos ϕ 1 3A: Cos ϕ 0,4
Sensitivity settings	3 (standard maximum sensitivity)
Twilight sensor	Adjustable between 35 – 1,000 Lux (standard 1,000 Lux)
Turn-off delay relay	Relay 10 seconds – 45 minutes (standard 15 minutes)
Turn-off delay sound	2 – 12 minutes (standard 6 minutes)
Detection angle	Approximately 130° – 140° (at 2.5 metres)
Working environment	0 °C - +40 °C
KEMA-KEUR (certificate)	Yes
Warranty	5 years

Measurements

MD-O Build-in

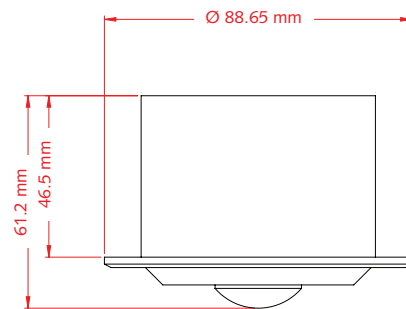

MD-O Surface mount

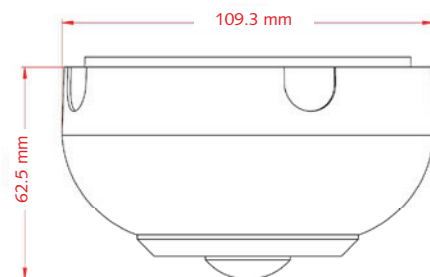

Technical data subject to change.



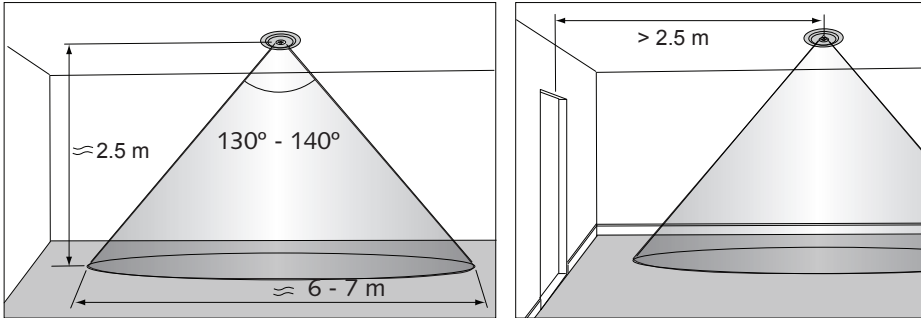

MD-O PRESENCE DETECTOR

IP20

Detection range



Versions





Built-in detector 3 m cord	Surface mount detector	Connection Kit 3 pin Wieland® connection	Potential free contact
			
Product code	Product code	Product code	Product code
MD-O-3M	MD-O-BO	MD-O-CK	MD-O-SWPV

Technical data subject to change.

MD-O PRESENCE DETECTOR

IP20

MD-O Presence detector accessories

Protective basket		Produktcode
	<ul style="list-style-type: none"> In combination with a protective basket, the MD-O detectors are also suitable for use in sports halls 	MD-O- basket (square)
	<ul style="list-style-type: none"> Or in situations that the MD-O needs extra protection against damage caused by an impact. 	
Remote control		Produktcode
	<ul style="list-style-type: none"> In combination with the TR61 remote control it is very easy to adjust the MD-O-presence detector to your needs. 	TR61
Connecting cable		Produktcode
	<ul style="list-style-type: none"> Wieland cable with protective earth (earth pin) connector. 	Power_cord_3_S-W
	<ul style="list-style-type: none"> Length 3 metres 	
	<ul style="list-style-type: none"> Together with the connection kit, the connecting cord makes installation of the MD-O very easy. 	
Connecting cable		Produktcode
	<ul style="list-style-type: none"> Wieland® cable with a male and female connector 	Connection_cord_3-W-W (3 metres)
	<ul style="list-style-type: none"> Together with the connection kit, the connecting cord makes installation of the MD-O very easy. 	Connection_cord_5-W-W (5 metres)
	<ul style="list-style-type: none"> Connecting cords can be used to link the luminaires. 	
Connection Kit		Produktcode
	<ul style="list-style-type: none"> By using the connection kit, installing and linking the presence detectors is a doddle. 	Connection_kit_MD-O
	<ul style="list-style-type: none"> The connection Kit comes supplied with a 3 pin Wieland male and female connector. 	

Technical data subject to change.