

LED LINE INSTALLATION INSTRUCTIONS IP65

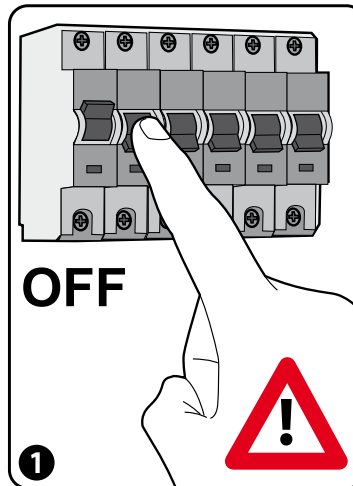
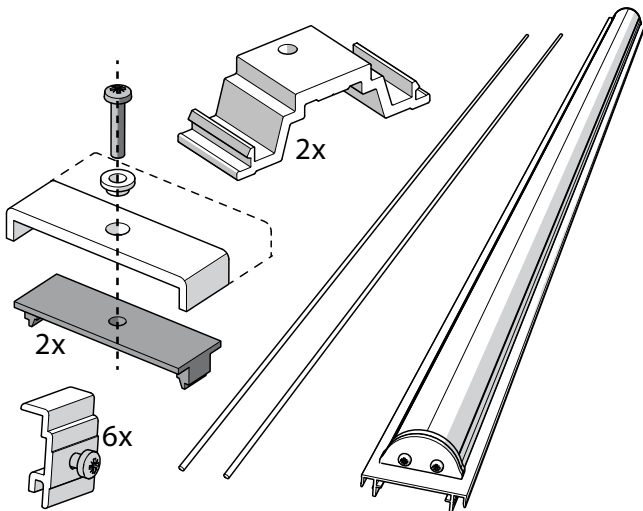

INTRODUCTION

Veko's LED line lighting can provide excellent light intensity at a height of up to 14 metres. Significant advantages of this line are the fast installation and long life span. The TWIST also has the advantage that the light bundle can be moved in different directions and the lamp is waterproof.

INSTALLATION

[1] Disconnect the mains before installation!

[2] Insert the wires of the LEDs into the connector on N, ⊕, and L1/L2/L3 {A}. Mount the connector on the wiring harness of the light line {B}.

[3] Mount the 7-pin connector on the wiring harness {A}. Fit the protective sleeve into the profile {B} and tighten the coupling nut {C}.

[4] Slide the bracket into the profile {A}. Replace the packing and end cap and tighten firmly {B}.

[5] Fit both rubber seals.

[6] Fit the light unit into the profile.

[7] Fit the end cap with the packing and the bolt with the rubber ring {A}. Tighten the bolt firmly {B}.

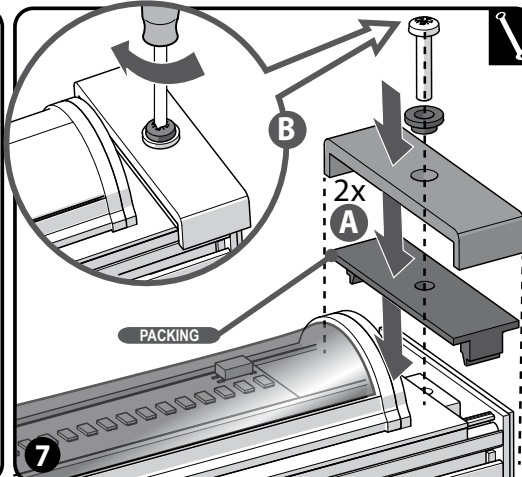
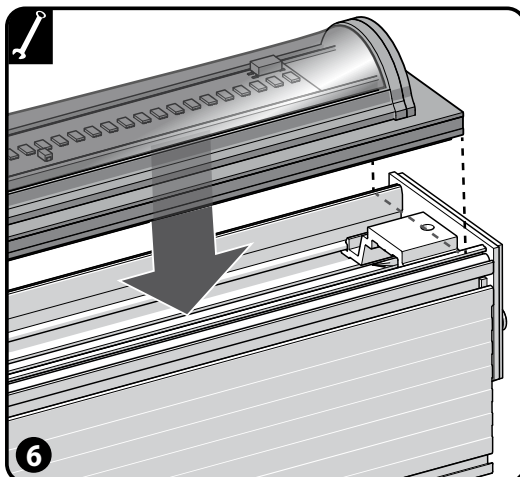
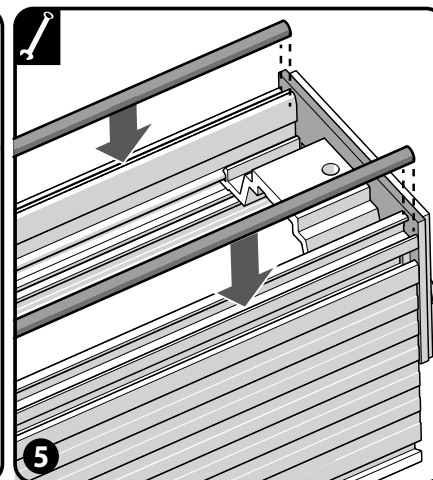
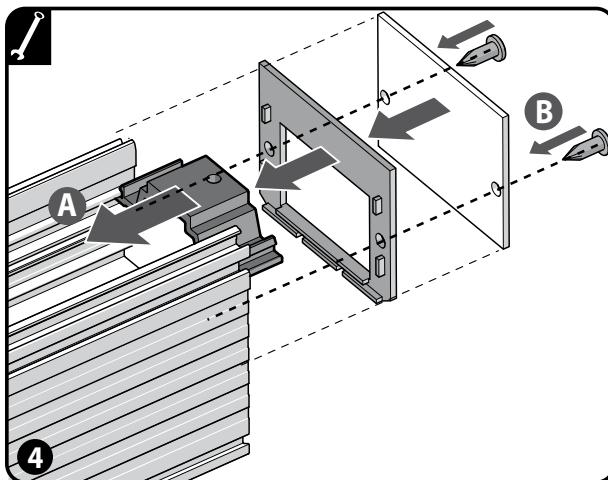
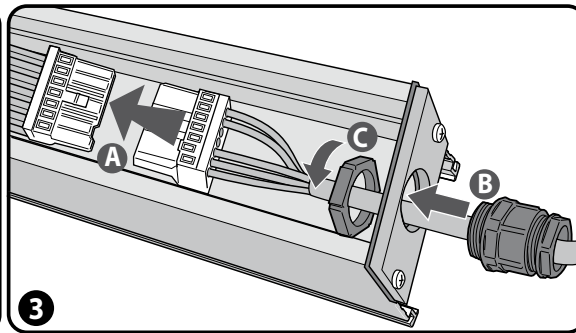
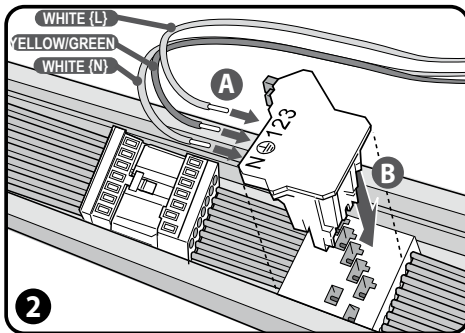

LED LINE INSTALLATION INSTRUCTIONS IP65

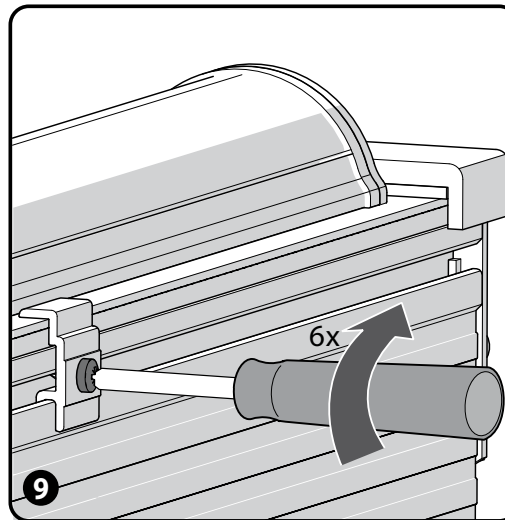
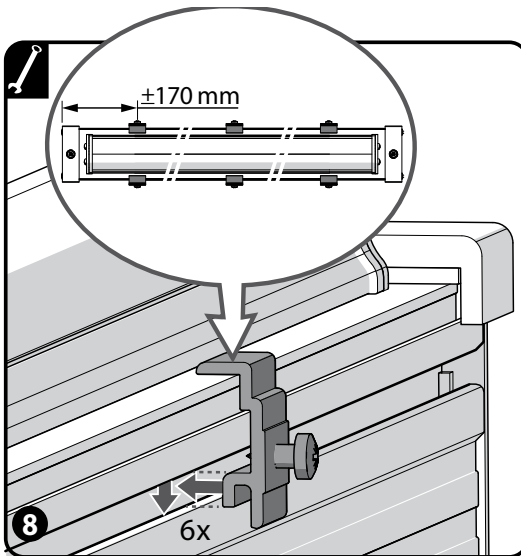

- [8] Fit the clips onto the profile and slide them into the notch.
- [9] Tighten the clips firmly.
- [10] The number of suspension points should correspond with the number of LED lamps to be installed.
- [11] To clean the lamp use only a cloth and a little water if necessary.

IMPORTANT

Always disconnect the mains before dismantling/replacing the LEDs! Detaching the LEDs from the driver while they are live will damage them.

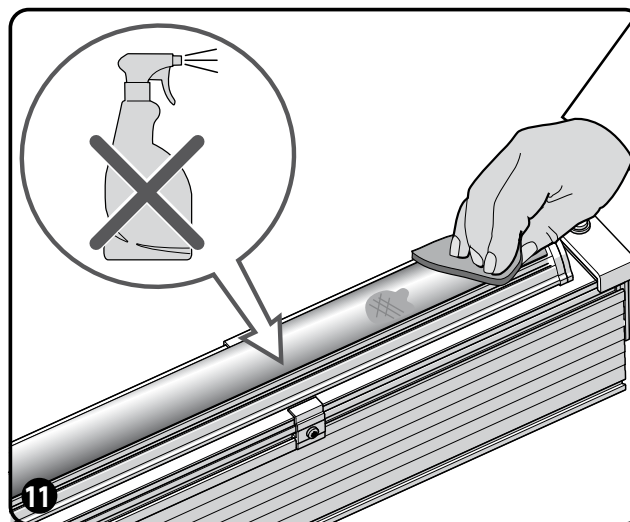
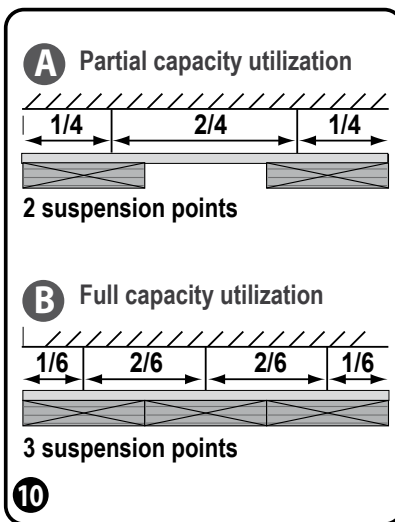

SAFETY

Disconnect the mains before connecting.

Any work on the 230V-mains and the installation of the LED line must be carried out by qualified electricians only.

All installation instructions must be followed.

When connecting the wiring, always take special note of corresponding colours.

Take all technical specifications of the appliance into consideration.

If in any doubt, please contact Veko Lightsystems Technical Department.

If you have any questions about the installation
e-mail montage@veko.nl
or call +31 (0)224 273 235

TECHN. SPECIFICATIONS

Mains voltage: **230 - 240 V, 50 Hz**
Subject to changes in design

If you have any questions about the installation
e-mail montage@veko.nl or call +31 (0)224 - 273 235



For more information on Veko Lightsystems,
product information and downloads, go to www.veko.com